

Features

- ◆ LED backlight
- ◆ Steel Chassis
- ◆ Resistive screen (optional)
- ◆ VGA input , 12V DC power jack
- ◆ DVI-I, RCA, S-Video (optional)
- ◆ 11~32V power (optional)

System

On screen display On the rear side

IO Port

Graphics 1 x VGA
 Option:
 1 x VGA
 1 x DVI-I
 1 x RCA
 1 x S-Video

Display

Display type 8" TFT-LCD
 Max. resolution 800x600
 Max. color 16.2M
 Luminance(cd/m²) 350
 View angle(H°/V°) 125/140
 Contrast 500:1
 Backlight lifetime(hrs) 40,000

Touch Screen

Type Resistive type
 Interface USB/RS-232
 Light transmission (%) 80%

Power

Power input 12V
 Optional:
 11~32V DC

Mechanical

Construction Steel Chassis
 IP rating None
 Mounting Panel mounting, VESA 75 x 75
 Dimension(mm) 191(W)x148(H)x42(D)mm
 208(W)x148(H)x42(D)mm(panel mount)
 Net weight(Kgs) 1.2

Dimensions

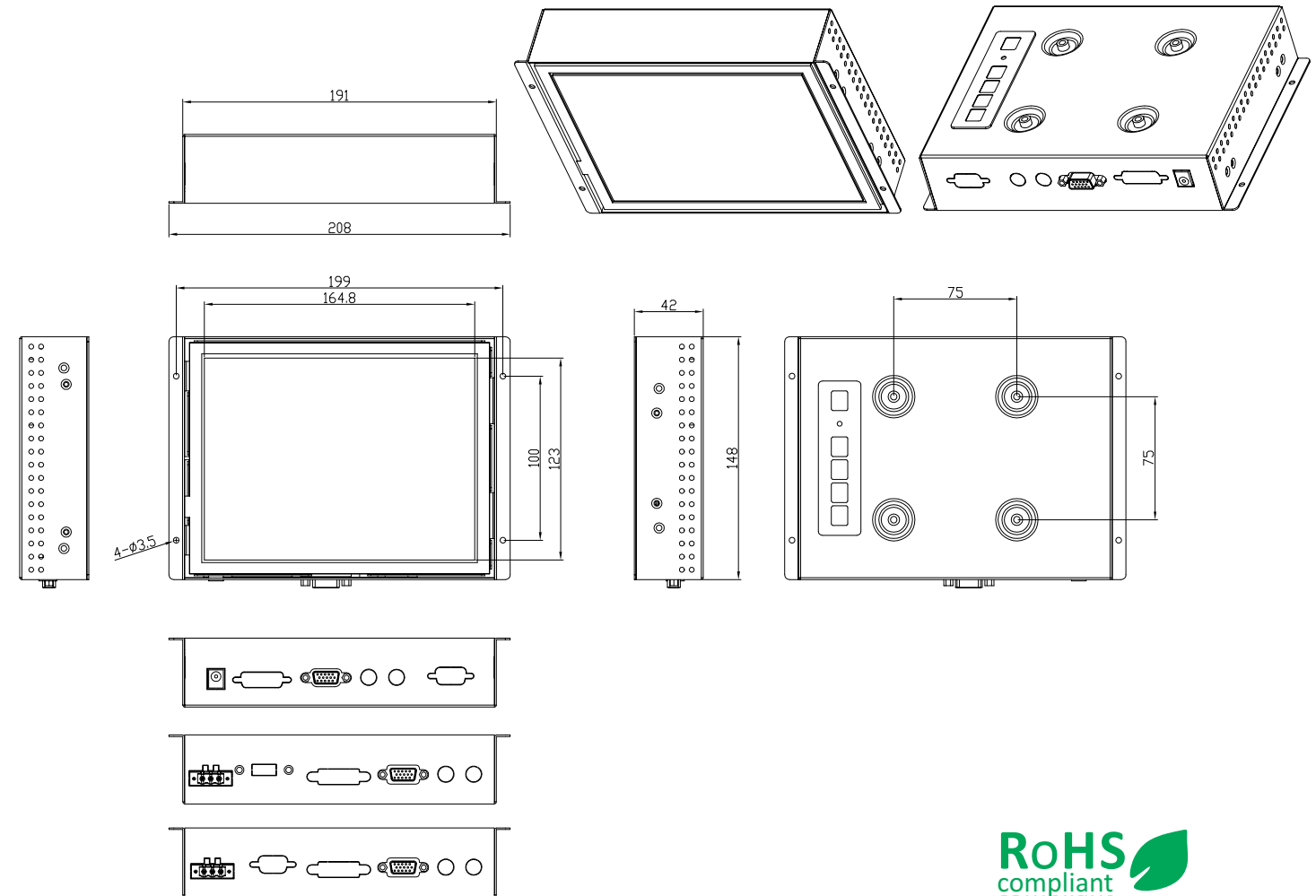

Environment

Operating temperature(°C) 0 ~ 50°C (32 ~ 122°F)
 Storage temperature(°C) -20 ~ 60°C (-4 ~ 140°F)
 Storage humidity 10 to 90% @ 40°C non-condensing
 Certification CE/FCC Class A

