

Features

- 10.1" LCD Panel, optional high brightness LED backlight LCD
- NXP i.MX8M Quad Plus Processor
- Fanless design
- Total IP66 with isolated M12 connectors
- Operating system: Android 10.0
- Wide range DC 9~60V power input
- CE/FCC/E Mark

Specifications

System	
CPU	NXP i.MX8M Quad Plus, 4x Cortex-A53 1.8 GHz
Memory	Onboard 4GB LPDDR4-3200MHz SDRAM
Speaker	2 x 2W IP65 Speaker
Function Keys	3 keys at Rear side: 1 x Power on/off 2 x Programmable(Default volume +/-) by user define
IO Ports	
I/O Interface-Rear	M12 Connectors: 1 x M12 Male, 3-pin for 9~60VDC input 1 x M12 Female, 8-pin for 2 x USB2.0 1 x M12 Female, 8-pin for RS-232/422/485 1 x M12 Female, 8-pin for 2-ch CAN BUS 1 x M12 Female, 8-pin for 1 x GbE LAN 4 x SMA connectors' holes for external antennas
I/O Interface-Edge	Under waterproof cover : 1 x USB2.0 Type-A connector 1 x Nano SIM 1 x Micro SDXC slot
Expansion	
Expansion slot	1 x Full-size mini-PCle socket (USB2.0) for HSUPA/LTE Module (for option) 1 x Full-size mini-PCle socket (PCle+USB2.0) for WIFI/BT Module (for option)
Others	1 x RFID Module (for option) 1 x Ambient Light Sensor (for option) 1 x 5MP Camera (for option)
Storage Space	
Storage	Onboard 32GB eMMC NAND Flash
Display	
Display Type	10.1" TFT-LCD
Max. Resolution	1280 x 800
Max. Color	16.7M
Luminance (cd/m ²)	350 nits, 1000 nits for option
View Angle	170(H) / 170(V)
Contrast	800:1
Backlight Lifetime	50,000 hrs
Touch Screen	
Type	Projected Capacitive Touch (default) Resistive Touch (option)
Interface	USB
Light Transmission(%)	Projected Capacitive Touch: over 90% Resistive Touch: over 80%

Dimensions

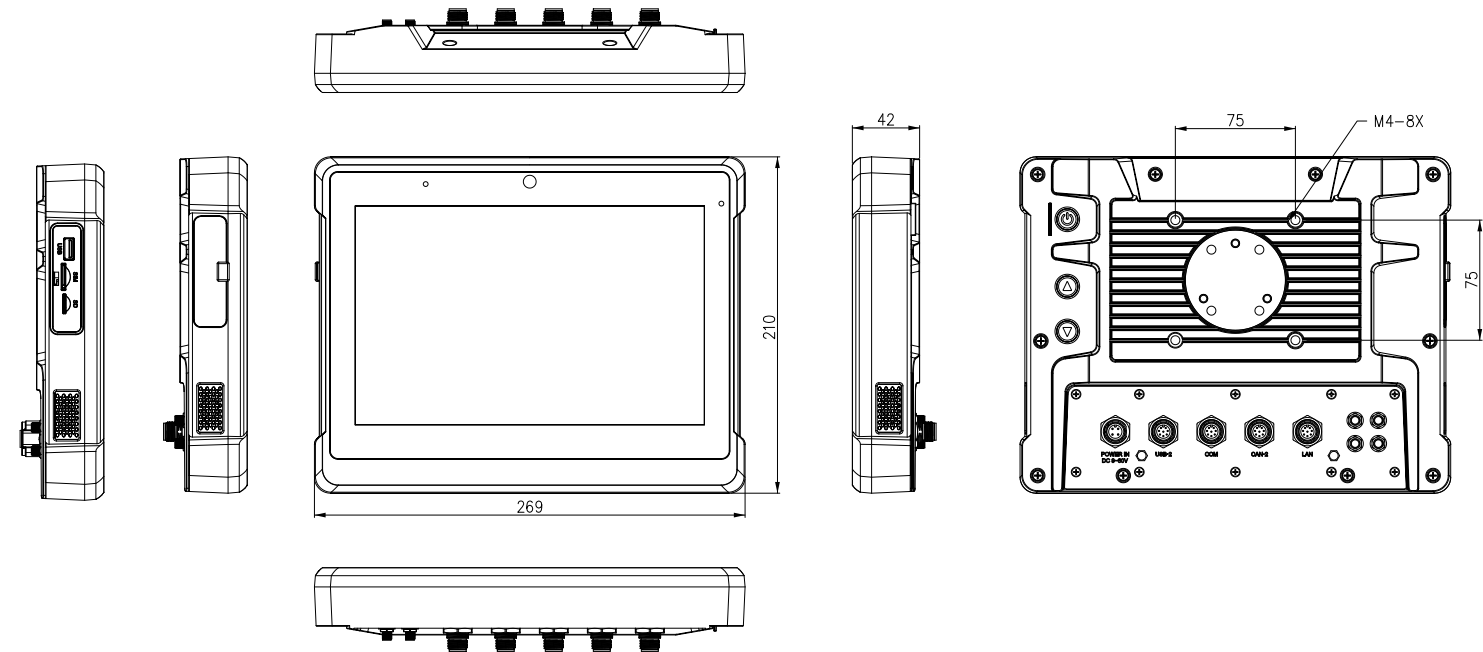

Power	
Power Input	DC 9~60V
Optional Power	DC 9~60V + Ignition / VCC Power
Power Consumption	MAX : 16W
Mechanical	
Construction	Engineering Plastic front/rear bezel
Mounting	Support VESA mount 75 x 75, RAM Mount (2.25" Rubber Ball "D" Size)
Cooling system	Fanless
Ingress protection	Complete IP66
Dimensions	269 x 210 x 42 mm
Net Weight	1.5 kg
Environmental	
Operating Temperature	0~50°C WT1: -20°C~60°C for option, WT2 : -20~70°C for option
Storage Temperature	-30~80°C
Humidity	10 to 90% @ 40°C, non-condensing
Certificate	Certificate CE/FCC Class A, MIL-STD-810H for vibration/ Shock, E MARK
Operating System Support	
Android 10.0	
Ordering Information	
APC-3103MP	10.1" WXGA total IP66 design plastic panel PC, NXP iMX8M Quad Plus Processor, DDR4 4GB on board, 32GB eMMC, M12 connectors, with projected capacitive touch, wide range 9~60V DC power input